

Electrical Safety Solutions Overview

Designed to meet ANSI, UL & CSA standards



Design the future
of energy



4 Ground-fault detection for ungrounded systems

8 Ground-fault detection for grounded systems

16 Isolated power solutions for healthcare facilities

20 Measuring and monitoring relays

22 Industry-driven solutions

30 Communications solutions



Design the future of energy

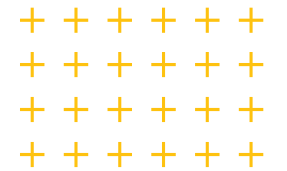

Since 1937, Bender's mission has been to make electrical power safe. Our wide portfolio of cutting-edge electrical safety and monitoring products are used in virtually every industry – healthcare, solar, oil and gas, electric vehicle, mining and many more.

With offices in over 70 countries around the world, Bender provides standard and customized solutions and services to meet our customers' individual needs.



Ground-Fault Detection

For ungrounded systems



Ungrounded systems offer an invaluable advantage – a first fault condition does not create an imminently hazardous situation. Early detection of ground faults allows critical systems to remain online while problems are resolved. Ground-fault detectors help reduce costs and maximize system uptime.

Bender's devices use the latest technology to detect and locate ground faults on ungrounded AC and DC systems, including systems with power conversion equipment, such as variable speed drives. Bender's ground-fault detectors are fully compliant with requirements such as NEC 250.21(B), NEC 250.167(A), and CEC 10-400(2).

Advanced ground-fault detection iso685 ground-fault detector



iso685

- Detects AC and DC, symmetrical and asymmetrical ground faults in ungrounded systems
- Digital display with real-time readout and on-board data trending graphs - no software required
- Adjustable alarm values up to 10 MΩ
- Built-in web server - connect to the iso685 via Ethernet to view device status and change settings
- Modbus/TCP communication included

Applications

- Mining, oil and gas, utilities, marine industries
- Single and three-phase AC systems
- DC systems
- General purpose 480 V and 600 V industrial systems
- Systems with variable frequency drives
- Main-tie-main configured systems

Panel-mounted HMI "S" order option

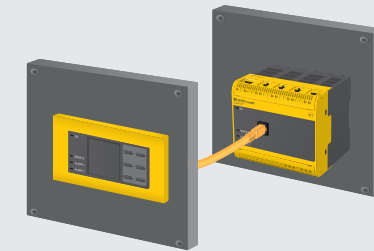

- Displays LEDs and push buttons on a separate panel-mount FP200 HMI
- No need to open panel door to view display
- Maintain low voltage at the panel front
- Simple, low voltage connection with RJ45 cable

Bus-tie breaker support "B" order option

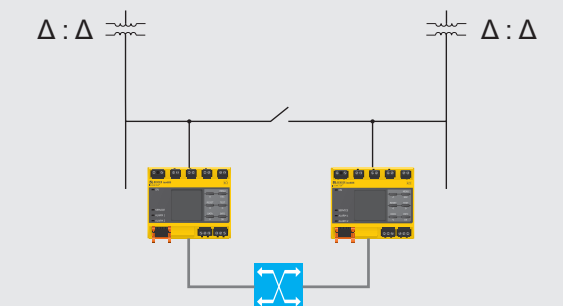

- Allows connection of multiple iso685 ground-fault detectors to systems connected via bus-tie breaker
- Ensures both sides of a tie breaker are continuously monitored
- Simple interconnection to an Ethernet switch for automatic monitoring control
- Connects to tie breaker logic for manual monitoring control

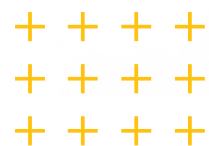

Online ground-fault location

EDS440 Series



EDS440 Series

- Use in combination with a Bender ground-fault detector to locate the fault on up to 12 channels per module
- Automate fault location while the system remains online, greatly reducing time required to find ground faults
- Wide selection of current transformers available for new installations or retrofit applications
- Get fast notification of located faults over Ethernet or Modbus/TCP
- Additional portable fault location system (EDS3090 series) available, allowing for fault location with a handheld device

Applications

- Single-phase AC, three-phase AC, and DC ungrounded systems
- Manufacturing facilities, ships, power plants, solar, and battery energy storage systems
- Motor control centers

Fast, automatic ground-fault location.

The EDS440 uses the latest technology to locate ground faults automatically in ungrounded AC and DC systems. Fault location takes place while the system remains online, without the need to open branch circuit breakers or disconnect equipment. Up to twelve circuits are monitored in parallel from a single device. Expansion is as simple as adding more modules.

- Automatic detection and location of ground faults down to the load level
- Saves operation downtime and man-hours by locating faults quickly while energized
- Supports virtually all conductor size requirements with a wide variety of current transformers
- Modular system allows for easy retrofitting/upgrading, including adding future branches

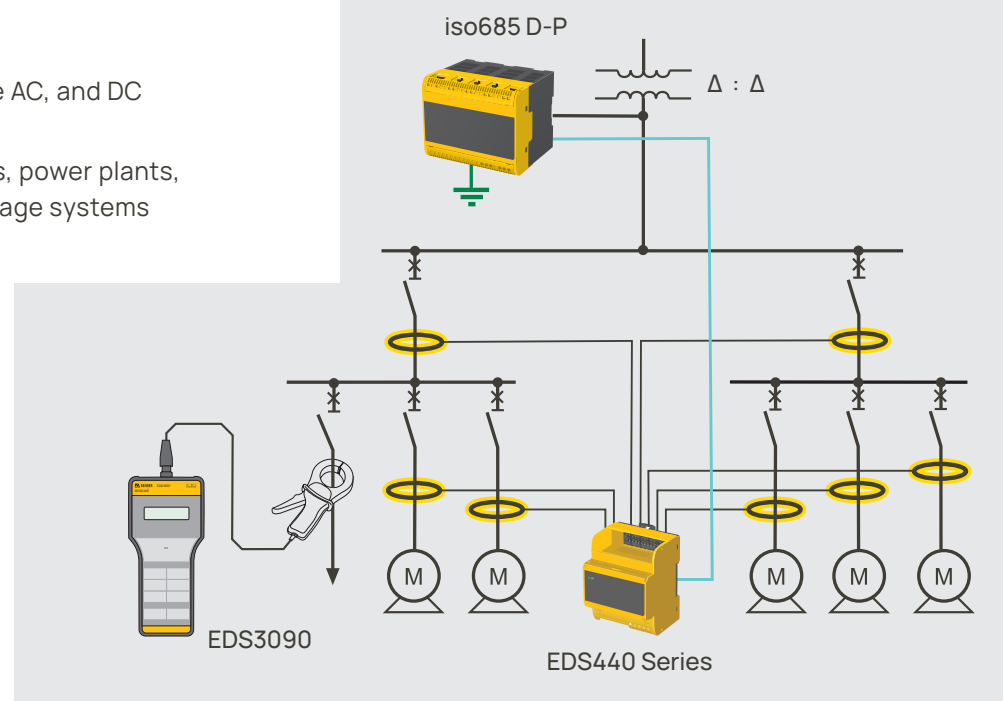

EDS series

Easy to install.

- Simple snap-in connection to iso685-D-P ground fault detector using Bender's backbone communication bus
- Remotely install EDS440 ground-fault location modules with simple two-wire connection to iso685
- All setup and status notifications take place centrally at the iso685
- Simple two-wire connections for Bender current transformers - one required per monitored circuit; available in a wide variety of shapes and sizes
- Split-core current transformers available for retrofit applications

Quick to notify.

- Relay outputs for alarm notification
- View the status of the iso685 and connected EDS440 devices remotely through Ethernet
- Clear identification of fault location by branch/channel using Bender's easy-to-use, browser-based interface built into the connected iso685, or with a connected COM465IP communication gateway
- Custom names for individual EDS440 branches
- Modbus/TCP support - Integrate fault location into industrial Ethernet networks

Portable ground-fault location tools

The EDS3090 series provides a complete, portable ground-fault location solution for ungrounded systems in a convenient package. Portable systems can be used standalone, or as a complement to permanently installed fault location systems.



- Quickly locate and identify ground faults with portable equipment
- Hand-held EDS3090 fault locator can be used in combination with permanently installed Bender ground-fault monitoring equipment
- Two sizes of split-core clamps included
- Ideal for contract service technicians and facilities with preventative maintenance programs

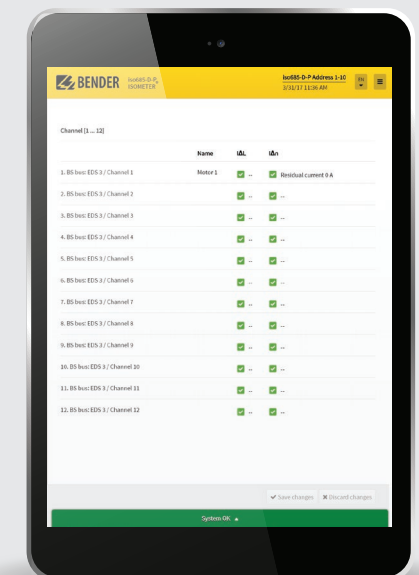

Ground-Fault Detection

For grounded systems

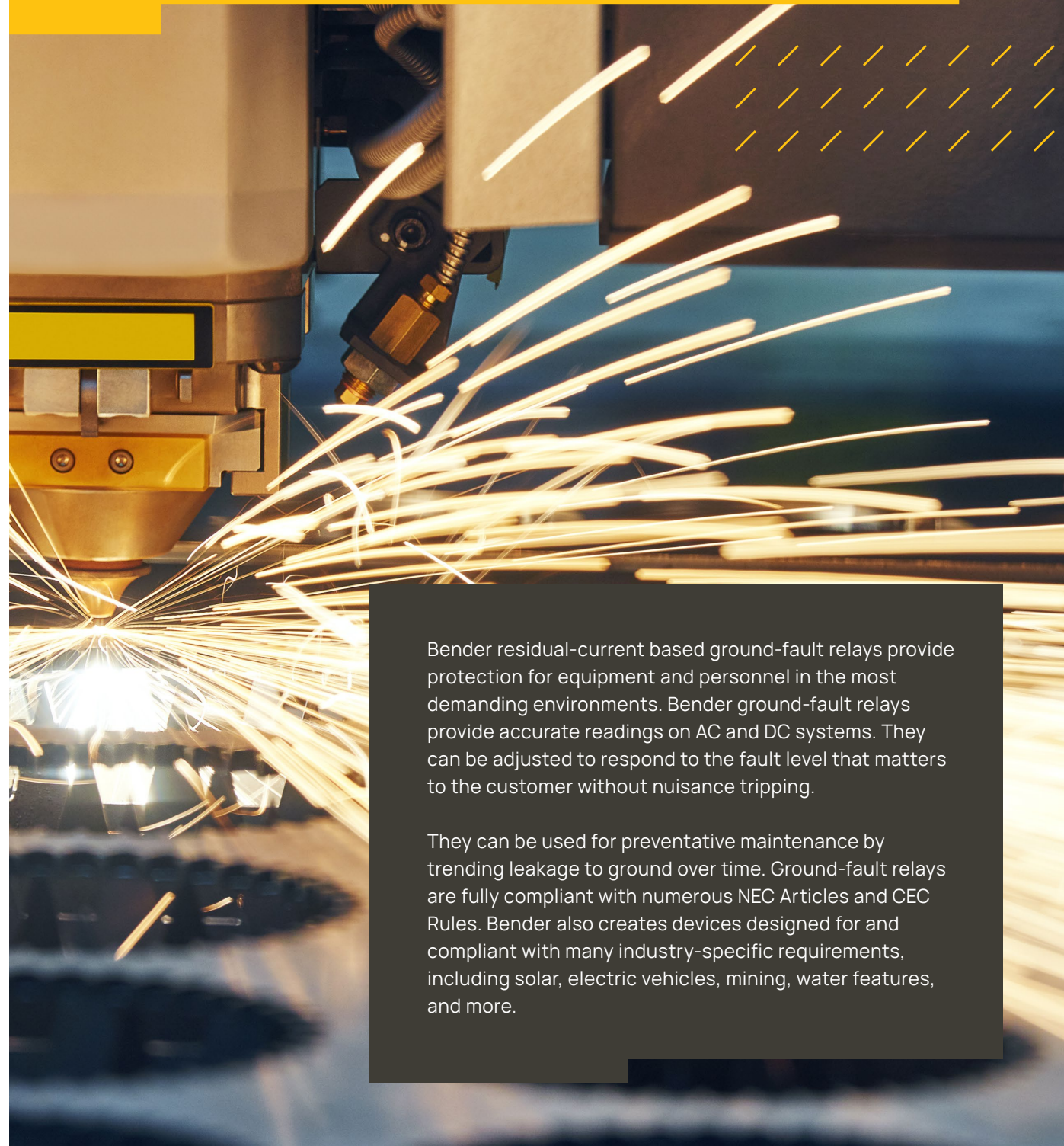

Bender residual-current based ground-fault relays provide protection for equipment and personnel in the most demanding environments. Bender ground-fault relays provide accurate readings on AC and DC systems. They can be adjusted to respond to the fault level that matters to the customer without nuisance tripping.

They can be used for preventative maintenance by trending leakage to ground over time. Ground-fault relays are fully compliant with numerous NEC Articles and CEC Rules. Bender also creates devices designed for and compliant with many industry-specific requirements, including solar, electric vehicles, mining, water features, and more.

AC and DC ground-fault protection RCMA, RCMS, and RCMB series ground-fault relays

RCM410R

- Residual current monitoring
- Helps eliminate unplanned outages
- Wide frequency response detects otherwise unseen problems
- Easily configured with dials or NFC
- Identifies faulted circuits before faults escalate



RCMS410

- 4 channel residual current monitoring
- Helps eliminate unplanned outages
- Identifies faulted circuits before faults escalate
- AC, pulsed DC, or AC/DC sensitive measuring for each channel
- Configurable frequency response
- Configurable via NFC and Bender Connect App



RCMB300 Series

- Residual current monitoring modules intended for measuring AC and DC fault currents in solidly and high resistance grounded systems. Modules can measure residual currents up to $I_A = 20\text{ A}$ in a frequency range of DC...100 kHz.
- RS-485 interface with Modbus RTU which can be used to communicate measured values and alarm values
- Exchangeable electronic enclosure without mechanical separation of primary conductors
- Compatible only with CTBC series current transformers



RCMA420/423

AC & DC ground-fault monitors

- True RMS readings
- Digital display with real-time readout eliminates the cost and need for a separate meter
- Adjustable pickup ranges of 10 mA to 10A and time delays (vary by device)
- Wide range of current transformer sizes for new installations or retrofitting into existing applications
- Two Form C (SPDT) contact outputs



RCMS490

Multi-channel AC or AC/DC ground-fault monitor

- True RMS readings
- Up to twelve separate channels with individual trip level settings providing economical and smaller footprint saving OEM's and end-users
- Digital display with real-time readout
- Form A (SPST) outputs for each monitored channel
- Network communications via gateway for web-based alarm notifications and Modbus/TCP integration



Applications

- Single-phase AC, three-phase AC, and DC systems
- Solidly grounded and resistance-grounded systems
- Systems with AC/DC power conversion equipment, such as UPS's and variable frequency drives (VFD's)
- Panel boards, main and branch feeders, individual load protection including: transformers, motors, generators, heaters
- Sensitive and reliable protection for heat trace systems

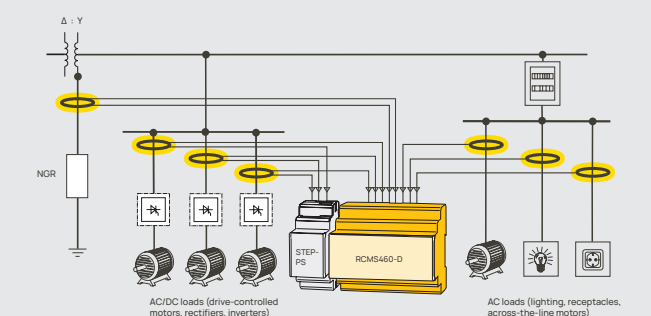

Resistance grounding solutions

HRG series and LRG packages

HRG Series

- Minimize fault current
- Continue operation and locate faults while the system remains online in a single-fault condition
- Schedule maintenance instead of performing emergency service and repairs
- Reduce probability of arc flash by as much as 95%

LRG Series

- Provides control of ground-fault current while still allowing enough current to trip existing non-sensitive ground-fault devices
- Provides some reduction in the risk of arc flash hazard and slight decrease in the damage during a ground fault when compared to a solidly grounded system
- Additional Bender ground-fault equipment can be added to provide early detection of insulation degradation before the fault escalates and requires tripping

Optional Features

- Pulsing contactor for simplification of fault location while the system is energized
- Feeder level ground-fault monitoring for safer and quicker ground-fault location
- Simple or advanced NGR monitoring for detection of neutral-to-ground path problems that could lead to lack of system grounding or safety hazards
- Local indication and remote communications to ground-fault and resistor-monitoring devices
- PLC complete with HMI for fault indication and feeder prioritization to allow automatic shutdown of lower-priority loads
- Separate control panel to monitor outdoor mounted NGRs, where applicable



<p>Series 1</p> <ul style="list-style-type: none"> Ground-fault detection Pulsing Analog metering Compact wall mount design 	<p>Series 2</p> <ul style="list-style-type: none"> Up to 60 feeders AC/DC ground-fault detection Pulsing Resistor monitoring Harmonic filtering 	<p>Series 3</p> <ul style="list-style-type: none"> Up to 120 feeders Second ground-fault protection Communication / fieldbus Touch screen HMI 	<p>LRG</p> <ul style="list-style-type: none"> Ample current is available for tripping LSIG breakers Current range is 100s to 1,000s of amps Available for medium-voltage applications
--	---	--	---

Refer to Bender's HRG/LRG brochure for more information

NGRM500, NGRM550, NGRM700, NGRM750

Neutral-grounding resistor monitors



NGRM500 / NGRM550

The NGRM500 detects NGR failure and ground faults in high-resistance-grounded power systems. The NGRM550 is used for low-resistance-grounded power systems.

Features

- Open and short (HRG only) NGR-failure detection
- AC/DC ground-fault detection
- Integrated web server, Modbus TCP/IP, and Modbus RTU
- HMI (Human-Machine Interface) that displays measured values and provides easy programming in selectable languages

Benefits

- Improves safety by monitoring of the grounding connection
- AC/DC ground-fault protection/detection to properly monitor non-linear loads, such as adjustable-speed drives
- Preventative maintenance – sensitive ground-fault pickup levels allow early warning of insulation degradation
- Simplified design - controls pulsing contactor in pulsing HRG systems
- Compact DIN rail mount solutions for application in smaller control panels also removes the necessity of wiring to the panel door



NGRM700 / NGRM750

In addition to the features of the NGRM500/550, the NGRM700 and NGRM750 offer unique packaging that allows easy installation of the base unit and a removable HMI for panel mounting.

Additional Features

- Designed for high-altitude use
- Detachable HMI
- Phase to-phase and phase-to-ground voltage monitoring

Additional Benefits

- Altitude rating of 5,000 meters above sea-level
- Program and display information without opening doors
- Faulted-phase indication

NGR and ground wire monitoring

For high-resistance grounded systems



RC48N

Ground fault and NGR monitor

- Adjustable ground-fault trip level and time delay
- Monitors NGR continuity on systems up to 5 kV using a CD1000 or CD5000 coupling device
- Wide range of current transformer sizes
- Two Form-C (SPDT) contact outputs
- Switchable wide-band or band-pass filter for 50/60 Hz
- DIN rail mount for quick and easy installation

GM420

Loop monitor for fixed-loads and overhead crane ground brushes

- Loop monitoring of the PE conductor in AC systems
- Measuring circuit providing a high resistance against extraneous voltages and indication of extraneous voltages
- Adjustable start-up delay, response delay and delay on release
- Adjustable switching hysteresis
- Digital measured value display via multi-functional LC display



RC48C

Ground fault and ground check monitor

- Adjustable ground-fault trip level and time delay
- Monitor integrity of ground conductor with E6-series termination module
- Wide selection of current transformer sizes
- Two Form-C (SPDT) contact outputs
- Switchable wide-band or band-pass filter for 50/60 Hz
- DIN Rail mount for quick and easy installation
- Trailing cable monitor used for mobile/movable loads
- Enhanced safety for pin-and-sleeve connector applications where a shorter pilot wire pin is used

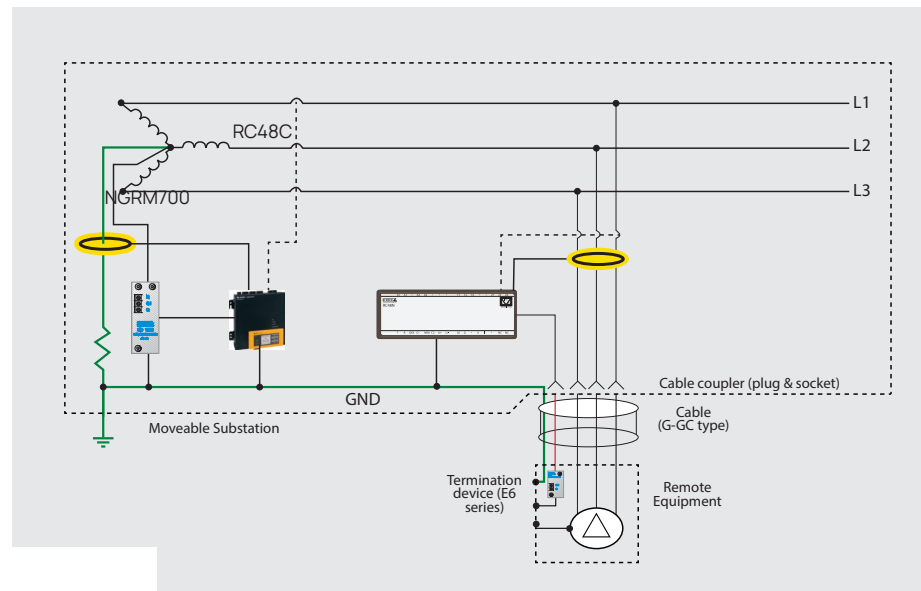

Current transformers

For Bender ground fault relays



CTAC Series and W-S Series

- Toroidal, solid-core current transformers
- Measures AC ground-fault current
- Ideal for general purpose branch circuit monitoring
- Compatible with Bender AC ground-fault relays, including RCM420 series, RCMS series, RC48C, RC48N, NGRM700, and EDS440 series



CTUB Series

- Measures AC and DC ground-fault currents (Type B)
- The CTUB101-CTBC combination is intended for connection to the RCMA420/423 series
- The CTUB102-CTBC combination is intended for connection to the RCMS460/490 series
- CTBC cores are available in 20, 35, 60, 120, and 210mm diameters, with or without an integrated magnetic shield



CTAS Series

- Split-core measuring current transformers
- Design allows current transformer to be opened through a locking button, allowing for easy retrofitting
- Compatible with RCM or RCMS series, and EDS fault location systems



WR Series

- Rectangular, solid-core current transformers
- Measures AC ground-fault current
- Ideal for bus-bar and large conductor monitoring
- Compatible with Bender AC ground-fault relays, including RCM420 series, RCMS series, RC48C, RC48N, NGRM700, and EDS440 series



WS Series

- Rectangular, split-core current transformers
- Measures AC ground-fault current
- Ideal for retrofit applications
- Compatible with Bender AC ground-fault relays, including RCM420 series, RCMS series, RC48C, and EDS440 series

Industrial control panels

LifeGuard® protection panels

LifeGuard®

- Ground-fault interruption for single or three-phase circuits
- Models for 20, 60, and 100-A circuit protection
- All models can be used from 120 to 600 V on 2, 3, and 4-wire circuits
- 6-mA (fixed) inverse-time or field-adjustable definite-time trip characteristic
- Grounded-neutral protection
- Compatible with systems and circuits with variable-frequency drives (VFDs)
- Easy-to-install NEMA 4X polycarbonate or stainless-steel enclosure or open styles



Protection against nuisance tripping.

- Inverse trip time curve minimizes nuisance tripping while maximizing protection
- Trip curve exceeds requirements specified by UL 943
- Measures true RMS value down to 0 Hz (DC)
- Quicker trip time at higher fault currents
- Advanced filtering circuitry
- Grounded neutral protection - helps to prevent accidental, multiple neutral-ground bonding downstream in the system

Benefits

- Protect against both AC and DC ground faults
- Certified to UL 508A
- Certain models feature a tripping time of 25 ms at leakage currents of 250 mA and above

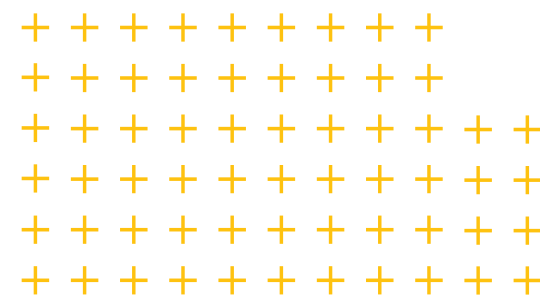

Service entrance fault protection

CMGF420 ground fault relay



CMGF420

- UL 1053 listed service entrance ground fault relay
- Meets or exceeds requirements of NEC 230.95, NEC 700.6(D), and CEC 14-102 when paired with appropriate equipment
- Small form factor - easily integrable into switchgear
- 60 A to 1200 A trip-level range
- Supports 600:1 or 1000:1 current transformers
- Digital display with real-time leakage-current reading
- Simple connection to shunt-trip breaker
- DIN rail, screw, or panel mounting (panel mounting requires optional mounting kit)



Isolated Power Equipment

For healthcare facilities

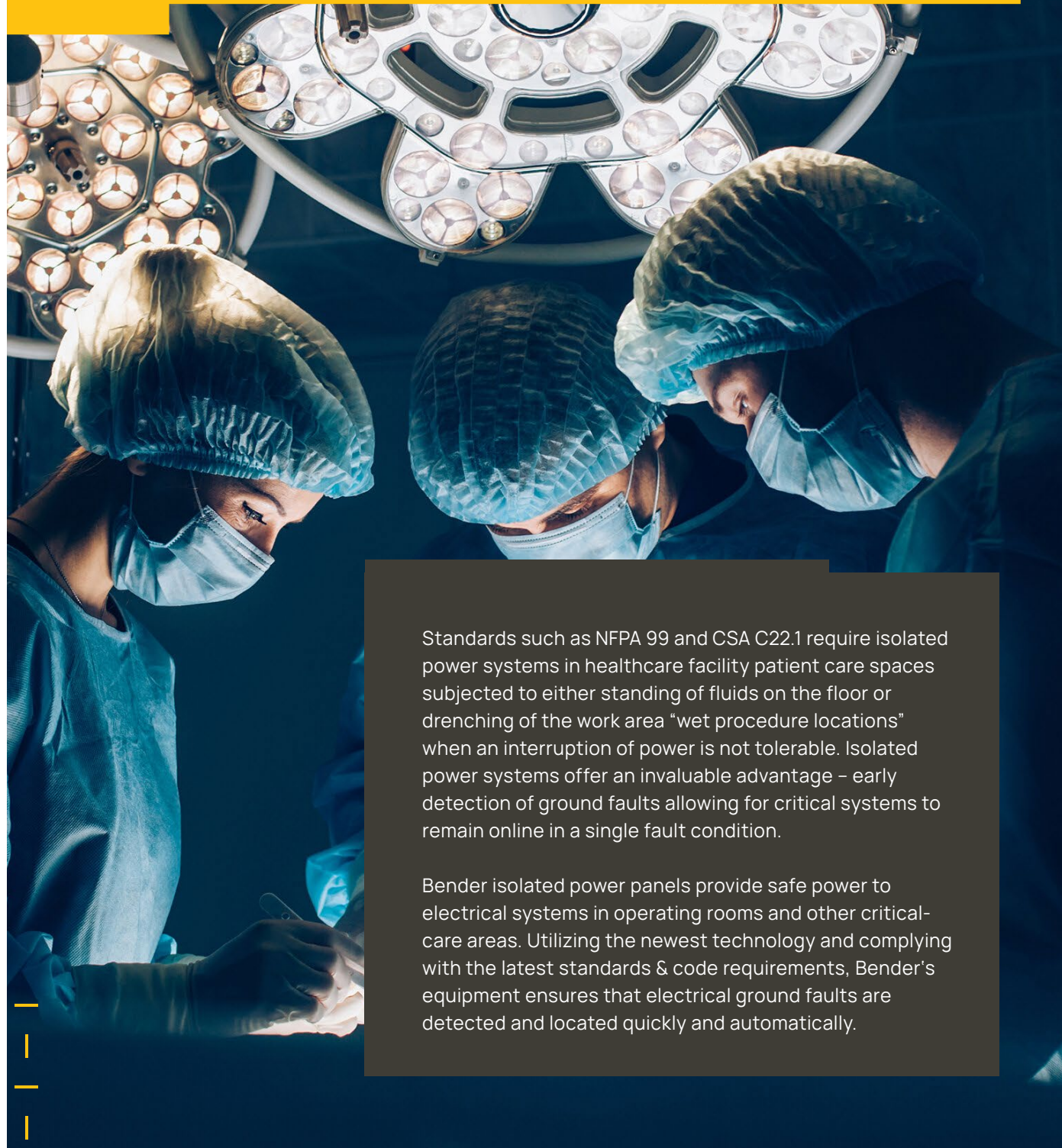

Standards such as NFPA 99 and CSA C22.1 require isolated power systems in healthcare facility patient care spaces subjected to either standing of fluids on the floor or drenching of the work area "wet procedure locations" when an interruption of power is not tolerable. Isolated power systems offer an invaluable advantage – early detection of ground faults allowing for critical systems to remain online in a single fault condition.

Bender isolated power panels provide safe power to electrical systems in operating rooms and other critical-care areas. Utilizing the newest technology and complying with the latest standards & code requirements, Bender's equipment ensures that electrical ground faults are detected and located quickly and automatically.

Protecting patients and staff

- Equipment designed in strict compliance with many electrical standards worldwide, including NFPA 99, NFPA 70, CSA Z32, and UL 1047
- The latest in line isolation monitoring technology, providing advanced warning of faults to help reduce downtime and increase operational efficiencies
- Supplemental alarms including transformer load, temperature, and voltage to minimize risk of electric shock and fire
- Branch location of ground faults quickly and automatically while the system is online
- Fast notification to facility staff with digital remotes, communication, and integration into facility networks



LIM2010

- The LIM2010 Line Isolation Monitor (LIM) measures the Total Hazard Current (THC) in an isolated (ungrounded) AC system.
- Alarms when system insulation begins to degrade
- No interference with electrical equipment
- Works on both 50 Hz and 60 Hz systems (100 -240 VAC)
- Audible and visual alarm indication
- The Total Hazard Current is calculated by measuring the system's leakage impedance to ground
- Total hazard current (THC) adjustable, 2 mA / 5 mA per local requirements
- Measures both system resistance and impedance
- Additional alarms including transformer overload and over-temperature, over-voltage and under-voltage, ground connection, and more
- Two programmable voltage-free SPDT contacts
- Color-coded bar-graph display, indication LED's, digital current meter (mA), and condition display
- Automatic self-calibration and self-check

Isolated power panels

- UL 1047 listed isolated power panels for healthcare facilities
- Single-phase isolation transformer
- Primary circuit breaker
- Configurable for up to 16 circuits
- Includes LIM2010 line isolation monitor
- Modular system allowing for easy future system upgrading in the field
- Many configurable options available: receptacles and ground jacks, PLC-controlled breaker, load monitoring, integrated fault location, and more



Online, automatic fault location

- Fast, automatic location of ground faults while the system remains online with the EDS441 ground-fault module
- Reduce down-time and maintenance costs
- Indication of faulty circuit shown on EDS441, connected remotes, and communication gateways
- Available integrated into panel, or available separately to retrofit into existing installations
- Modular design allows for individual ratings specifications per branch / channel
- Installation kit includes easy-to-install current transformer assemblies

1 LIM2010 line isolation monitor

- Controls line isolation monitoring, main load monitoring, and fault location

2 Ground fault location and branch load modules

- EDS441: Automated branch ground-fault location
- CMS460: Individual branch load monitoring

3 CP series touch control panel

- All-in-one solution that can control and monitor numerous aspects of the operating room environment
- 5-inch, 7-inch, 15.6-inch, and 24-inch easy to use touch screen interface

4 Communication gateways

- COM465IP: Provides web-based interface for remote panel status, visualizations; Modbus TCP gateway

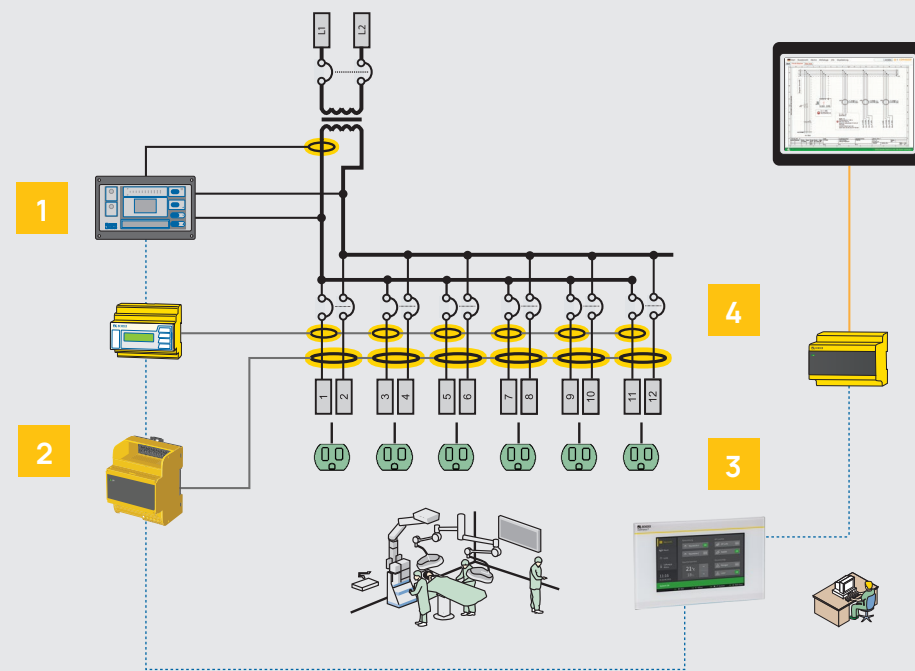

Services for isolated power systems

Bender services offer a wide range of benefits to ensure optimal performance of your isolated power systems including:

- Complete services for new isolated power systems regardless of original manufacturer
- Training for hospital staff to ensure proper understanding, use and care of isolated power system
- Cleaning and vacuuming of panel interior
- LIM and accessory software updates*
- Testing performed utilizing Bender-developed, industry leading LT3000 test instrument
- Electronic documentation provided as required by accredited agency compliance audits
- Comprehensive testing & evaluation for annual and bi-annual testing required by NFPA 99, NEC and many accredited agencies

Testing & evaluation of your isolated power systems includes:

- Measurements of hazard current & calculations of system impedance
- Receptacle ground tension test
- Ground continuity testing
- Receptacle polarity verification
- Touch voltage verification of exposed metal surfaces
- Line Isolation Monitor (LIM) functionality verification via external fault testing
- Verification of panel circuit breaker terminal torques

Bender's isolated power system (IPS) Panel



Bender's LIM2010 line isolation monitor



Bender's LIM2010 is ideal for retrofitting applications regardless of the current LIM's make and model. For the majority of applications, no metal cutting is needed and simple instructions facilitate a fast changeover. Its automatic self-calibration, self-check and digital display allow for yearly performance testing as opposed to bi-annual testing for analog LIMs (per NFPA 99).

Bender's LT3000, an industry-leading testing instrument



* Software updates pertain only to qualifying Bender manufactured equipment

Measuring and Monitoring Relays



Protective relays from Bender provide a multitude of measurement options outside of ground-fault protection, including voltage, current, ground continuity, and more. Relays like the VME420 and VMD420 provide a wide range of alarms in a single relay, including over-and undervoltage, frequency, and more.

Bender monitoring relays include a number of state-of-the-art features, such as digital displays showing real-time measurements, highly configurable contact outputs, and more.

Voltage and current relays For AC and DC systems



VME420, VMD420, and VMD461

Voltage relays

- True RMS readings
- Models for single-phase AC, DC, and three-phase AC
- Digital display with real-time readout
- Precise alarm values entered via digital display and pushbuttons - no need for guesswork with potentiometer dials
- Two Form-C (SPDT) contact outputs
- Outputs are individually configurable to trip on any combination of alarm types

Applications

- Single-phase AC, three-phase AC, and DC systems
- General industrial use
- Motor protection
- Battery systems
- Dump load controllers and transfer switches
- Pumps, generators



CME420 and CMD420

Current relays

- True RMS readings
- Models for single-phase and three-phase AC
- Supports direct system connection, or connection through current transformers with 1A or 5A secondaries
- Entering CT ratio allows for real-time display of primary side current
- Triggers on overcurrent and/or undercurrent
- Digital display with real-time readout
- Two Form-C (SPDT) contact outputs
- Outputs are individually configurable to trip on any combination of alarm types

Applications

- Single and three-phase AC systems
- General industrial use
- Motor protection
- Pumps, generators
- General load current monitoring

Industry-Driven Solutions



Bender's success goes beyond general purpose equipment. Bender works closely with customers in various industries to create innovative products that operate in even the most unique conditions. Bender solutions provide added value to your business.

From conventional industries like oil & gas and mining, to newer markets like solar, wind, and energy storage - Bender products are continuously evolving to meet the ever-changing needs of customers around the globe.

Solar Power and Energy Storage



As power generation around the world evolves, more smart grids are implementing efficient, environmentally-friendly methods of generating and storing electricity. Advances in photovoltaics and battery storage systems bring new challenges in protection of personnel and equipment.

Smart grids demand smart electrical safety. Bender monitoring equipment uses the latest technology to ensure accurate, quick readings on solar arrays and battery systems of virtually all sizes. With a wide range of communication options, Bender devices integrate easily into industrial networks - including Ethernet and Modbus.



iso1685P

Ground-fault detector

- Ideal for large-scale deployments of ungrounded solar arrays and energy storage systems
- Meets or exceeds industry code requirements, including NEC 690.41(B) (2017 edition), NEC 712.55, and CEC 64-066(1)(d)
- Works on systems with up to 3000 μF leakage capacitance
- Adjustable insulation-resistance trip value of 200 Ω to 100 k Ω
- Automatic data logging on microSD card
- Works with EDS440 to create fault location system
- Compatible with Bender communication systems



isoPV425 with AGH420

Insulation monitoring device for AC and DC systems

- For photovoltaic systems up to AC 690 V/DC 1000 V
- Separately adjustable response values 1 k Ω ...1 M Ω
- Automatically adapts to system leakage capacitance up to 1000 μF
- Measurement of system voltage (RMS) with undervoltage and overvoltage detection

Electric Vehicles (EV & EVSE)

From inside the car to charging stations, Bender devices provide a complete solution for mitigating risks of electric shock, equipment failure, and fire damage. They are designed specifically for integrating into electric vehicles, as well as level 2 and level 3 (fast DC) charging stations.

Designed in compliance with requirements such as UL 2231, NEC 625, and SAE standards, our equipment provides a simple, integrable solution for your electrical safety requirements.

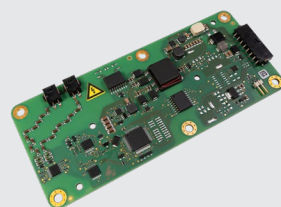

iso175

Isolation monitor interrupter

- Constant monitoring of the entire electrical system for loss of isolation
- Compatible with all electric vehicles currently present on the market
- Superior measurement for the entire circuit - from battery to the drive train
- Fully adaptive to varying Y-caps



RCMB121

CCID5, 20, level 1&2 EVSE ground fault detector

- Fulfills UL & IEC requirements
- Charge current interruption on ground faults
- AC & DC capable
- High accuracy over a wide temperature band
- Sensors incorporate all necessary electronic circuitry

isoCHA425

DC fast charge IMI isolation monitor interrupter

- Fulfills UL and SAE requirements
- Provides electrical safety from shock hazards
- CCS and Chademo
- Accurate monitoring and interrupting of high-voltage DC circuits



RCMB104 & CTBC17

Measuring current transformer

- Cost-optimised PCB variant for PCB mounting (can be soldered or screwed)
- Fulfills UL & IEC requirements
- Precise mA readings and trips
- AC & DC capable
- High accuracy over a wide temperature band
- Separate electronics and sensor

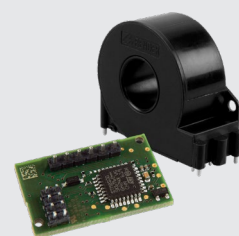

Marinas

Electric boats, refrigerators, and lighting – today's marinas and residential docks are filled with potential electrical hazards. Ground faults are a leading cause of death, injury, and equipment damage in marinas. Fault current leaking to the water creates risks of boat corrosion and electric shock drowning (ESD) for people swimming or wading in the water.

MarinaGuard® is the result of years of direct involvement with the marina industry. MarinaGuard panels are built for protection at the main distribution panel down to individual slips. Continuous monitoring for ground faults helps mitigate the risks to people, boats, and equipment – while providing a simple, streamlined system for technicians and harbor owners to use.

MarinaGuard®

Ground-fault monitoring panel

- Meets or exceeds requirements of NEC 555.35 (A) & (B)(1), 555.53 & 682.15 (B) (2023 edition); NEC 555.32, 555.35 (A)(1) & (3), 555.53, & 682.15 (B) (2020 edition); NEC 555.3 & 682.15 (2017 and earlier editions); and CE Code 78-052 and local jurisdictional requirements
- Single-channel and twelve-channel models (MG-1 & MG-T)
- Trip outputs for connection to external shunt-trip circuit breakers
- Strobe light externally mounted onto lockable type 4X rated enclosure, suitable for outdoor use
- UL 1053 Listed Ground-Fault Protection of Equipment, as required by the NEC



Oil, Gas, and Petrochemicals



Bender offers electrical safety solutions for most segments in the petroleum industry – onshore, offshore, subsea systems, pipelines, refineries, maintenance and more. Most petroleum-industry segments utilize electrical systems that are required to operate continually. Shut downs due to electrical faults are typically very costly. The use of ungrounded systems (floating systems) or high-resistance-grounded (HRG)

systems with appropriate monitoring devices from Bender can significantly reduce downtime. Protection of personnel must also be ensured and shouldn't be compromised. Automatic fault location and remote communications provide critical "system-health" information to key personnel. The quicker a fault can be located, the sooner it can be repaired.

Ungrounded

iso685

- Accurate insulation monitoring that adapts to the condition of the system
- Standard communication port for remote monitoring and control
- Data logging to trend insulation resistance over time
- Coupling devices available for higher voltage applications
- Configurable solutions for multiple bus and tie breaker systems
- Offline insulation monitoring for motors



EDS440

- Automatic ground-fault location for ungrounded AC and DC systems
- Locates ground faults while the system remains online
- Up to twelve channels per EDS440, up to 80 EDS440 evaluators per insulation monitor
- Compatible with a wide range of current transformers



Grounded

HRG Series

- Turnkey resistance-grounding packages customized for the system being protected
- Solutions for retrofit or new construction
- Communications capable relays to provide enhanced information on the system
- Pulsing ground-fault systems enhances online fault location ability
- Better protection for VFD and other non-linear loads by using AC/DC- full frequency monitoring devices



RCMS490

- Safer and faster fault location with feeder level or load level ground-fault monitoring
- Up to twelve channels per RCM490
- Economical and space-saving design
- Digital display with real-time readings and on-board menu
- Reduce maintenance of installed ground-fault equipment using self-monitored relays and current transformers continuity monitoring



Rail & Transit



Improving electrical safety and increasing availability are essential elements of a smooth railway operation. This applies to signal bungalows, signal systems, operational buildings, tunnels, bridges, and to all rolling stock in the form of locomotives and rail cars.

Bender rail system solutions predictively reduce downtime for your rail system by continuously monitoring electrical system conditions of equipment on all types of rail applications. This provides advanced notice of preventative maintenance requirements which reduces traditional scheduled maintenance costs and downtime.



isoRW685W-D

- ISOMETER® for ungrounded AC systems with galvanically connected rectifiers or inverters and for ungrounded DC systems
- Automatic adaptation to the system leakage capacitance up to 1000 uF
- Connection monitoring of the measuring lines
- Freely programmable digital inputs and outputs
- Communications with BCOM, Modbus TCP, and web server



isoRW425

- Ground-fault monitoring device for ungrounded AC and DC IT systems
- Monitor control circuits in railway vehicles according to EN 50155
- Insulation impedance measurement (Z mode) for 50 Hz or 60 Hz
- Automatic adaptation to the system leakage capacitance up to 300 µF
- Measurement of the nominal system voltage (RMS) with undervoltage and overvoltage detection

Mining & Tunnel Boring



Mining describes the exploration, development, extraction and preparation of materials from the earth using mechanical and electrical equipment. In this extreme working environment, human safety depends directly on the flawless functioning of the technology.

Protective devices not only increase safety, they also ensure smooth processes and maximum availability of the equipment and systems required to extract the mineral resources.

Powerscout Screen Showing NGR % Resistance & Temperature Over Time

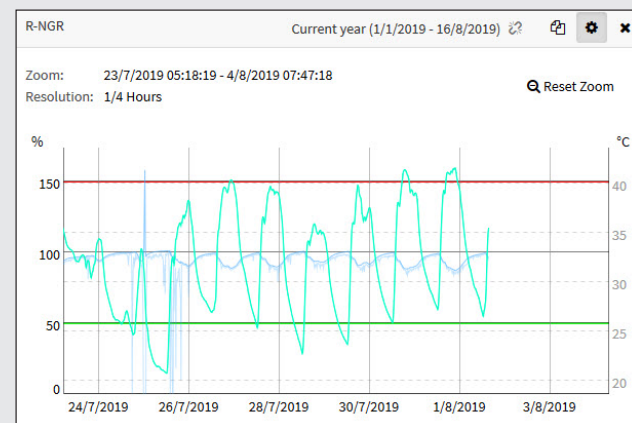

NGRM500 and NGRM700



- Monitoring continuity of neutral to ground resistor paths is required by many mining codes
- Critical for safety and control of touch potential on trailing cable fed loads
- Fixed equipment: used for best practice for substations powering equipment such as mills, crushers, pumps and conveyors
- Select the NGR monitor that best fits the application
- Remotely monitor Resistance to Ground of Substations to improve safety

RC48C and RCMS490



- Trailing cable ground-fault and ground-check loop monitoring for mining equipment connected with portable power cables (trailing cables)
- Enhances safety by monitoring continuity of ground connection to the portable load
- Used on cables and cable coupler systems that feature a pilot wire and pilot pin
- Multi-channel load ground-fault detection devices are available to provide AC & DC protection

Renewable Energy



As power generation evolves to meet modern demands, more smart grids require efficient, environmentally-friendly methods of generating and storing electricity. The evolution of power generation into wind and renewable industries brings new challenges in mitigating the risk of electrical shock, equipment damage, and fire.

Bender's monitoring equipment uses the latest technology to ensure accurate, quick readings on renewable energy systems of virtually all sizes. With a wide range of communication options, our equipment integrates easily into industrial networks to stay informed of your system's health at all times.

VMD460

- Straightforward commissioning
- Network and system protection with default basic programs for national standards and regulations
- RS-485 communications interface (data exchange/parameter setting/software update)
- Continuous monitoring of the phase voltage and line-to-line voltage
- Remote shutdown via ripple control signal receiver
- History memory of last 300 events and faults with real-time clock-calendar time stamp
- Password protection for device settings
- Automatic disconnection device between a power generation system and the public grid



Communications Solutions

Bender provides a wide range of communications products to connect monitoring systems to facility technicians and management. A number of protocols are supported, ensuring interoperability with continually evolving technologies.

Web browser interfaces and HMIs provide an easy-to-use gateway to your system. Integrable communications brings Bender into your industrial network. Cloud-based solutions provide a scalable, secure solution for system status and analytics across multiple facilities and locations.

Communications gateways COM465IP and CP907



COM465IP

Communications gateway

- Adds supported Bender and third party devices to industrial communications networks
- Web interface compatible with mouse-based and touch-based devices
- Connects to standard Ethernet networks
- Monitor the status of devices and alarms across multiple communications protocols in a unified interface
- Supports Bender RS-485 bus, Bender Ethernet bus, Modbus/RTU, and Modbus/TCP (other protocols available on request)



CP907

Touch control panel

- 7" display with tempered and non-reflective glass
- Individual display contents: system overview or custom visual interface
- Monitoring and parameter settings of all capable Bender devices
- Visual and audible alarms in the event of a failure
- Multiple communications interfaces for third-party device integration and data transfer
- Easily adaptable for future changes due to latest hardware and continual software development





POWERSCOUT™ System uptime, redefined.

- A comprehensive, scalable, cloud-based solution for power system monitoring and analytics
- Trend and analyze ground faults, power quality, system condition, and more
- Manage multiple systems and locations from one web interface
- Collect and analyze data over months or even years using Bender's secure, managed hosting platform
- Setup wizards - create installation reports and visualization widgets easily with predefined drag-and-drop utilities
- Visualize systems with dashboards - graphs, trees, heat maps, and more
- Automated reporting capabilities
- Add compatible third-party devices
- Managed hosting services and local network installations available

Stay notified.

- Easy to use web-browser interface
- Unified status screen for connected devices across multiple communication protocols, including Bender RS-485 bus, BCOM (IP-based protocol), and Modbus
- Drill-down for each device shows detailed readings, including values and alarms for all single- and multi-channel devices
- Modern user experience, compatible with web browsers on mouse- and touch-based devices
- Create visualizations of facilities showing real-time device information
- Integrate third-party devices over Modbus/TCP
- Virtual set points - create custom conditional or mathematical alarms for one or more devices to tailor alarms to specific locations or applications

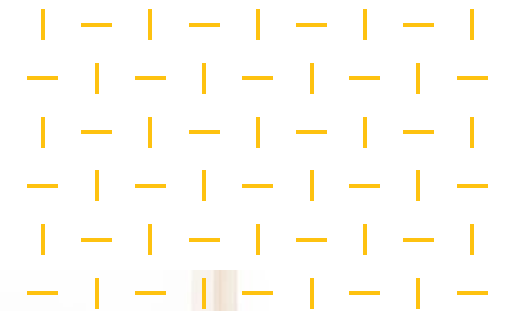
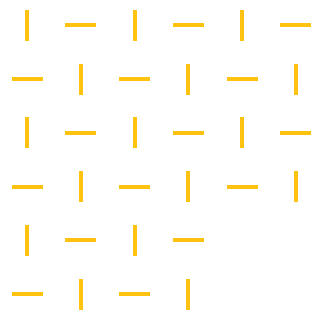

Technical & application information

Ungrounded systems

Ungrounded power systems

Ungrounded (also known as floating or IT) systems are power systems with no intentional connection to ground. Typical ungrounded power sources include 480 VAC and 600 VAC transformers in a delta configuration. Ungrounded systems are typically used to power critical equipment where a sudden shutdown must not occur. Examples of such systems include operating rooms in healthcare facilities, signaling systems, chemical manufacturing, and emergency backup systems.

The magnitude of fault current in an ungrounded system is dependent on the system voltage, the magnitude of the fault's resistance, and system capacitances to ground. In a first-fault condition, this magnitude is typically very small.

An example of a single-fault condition is shown in Figure 1. The circuit between the faulted system conductor and the other phases is very high impedance. Fault current will flow to the unfaulted phases through the system's distributed leakage capacitance. The resulting current is known as charging current, the magnitude of which is typically small.

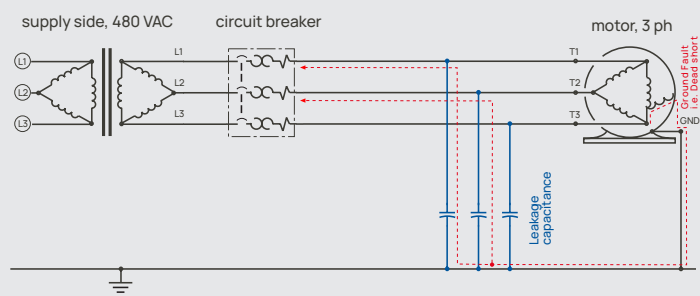

Figure 1: Ungrounded system in single-fault condition

While ground-fault impedance will vary, the first-fault scenario will not create sufficient fault current to trip a circuit breaker or typical ground-fault relay. Alternate methods of detection are necessary, such as monitoring the system's insulation resistance.

The active IMD on AC systems

Instead of monitoring for ground-fault current, active insulation monitoring devices (IMD) measure the system's resistance to ground, known as the insulation resistance. Even if a ground fault on a de-energized system is not generating current to ground, it will have a resistance associated with it. This resistance will vary based on the ground-fault severity.

The insulation resistance of the system will decrease proportionally to the severity of the ground fault. Insulation resistance may drop slowly over time, due to corrosion or degradation of wire insulation. It may also drop significantly in a short period of time, due to situations such as sudden damage to a feeder cable. Both situations require continuous monitoring and trending.

An active IMD continuously monitors the insulation resistance value. The device connects between the system conductors and ground. A continuous, line-to-ground measuring signal is injected into the system. The signal will monitor the secondary side of the supply transformer and all connected loads. If a path to ground exists, the signal will travel through it and return to the IMD, as shown in Figure 2.

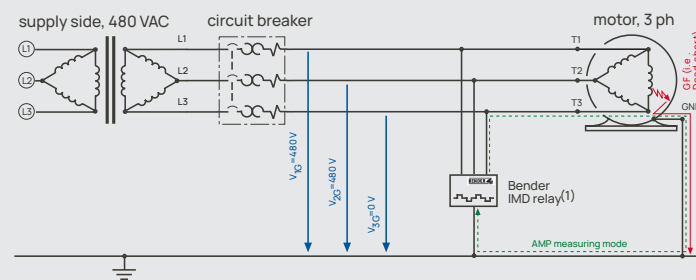

Figure 2: Ungrounded three-phase system with IMD

The IMD processes the signal and provides indication and outputs when the insulation resistance reaches a specified level. An IMD's alarm level is set in Ohms (Ω) as opposed to Amperes (A).

A quality insulation resistance level ranges from multiple kilohms ($k\Omega$) to megaohms ($M\Omega$). However, acceptable levels can vary by application. Varying factors include quantity and type of loads, age of installation, environmental conditions, etc. For example, some industries utilize an estimation of $100 \Omega/V$ to determine an alarm value.

The active IMD on DC and systems with power conversion equipment

Active insulation monitors function similarly on ungrounded DC systems. The device connects between the system and ground. The measurement signal will monitor the secondary side of the supply (such as a battery) and attached loads. An example system is shown in Figure 3.

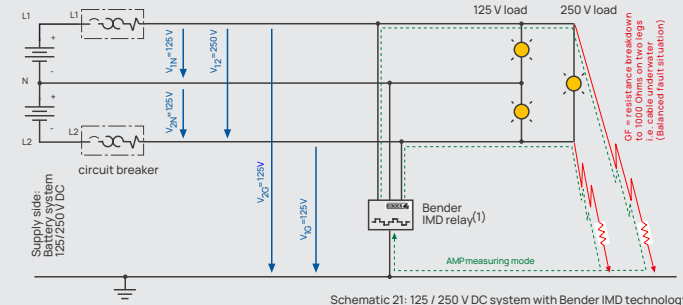

Figure 3: 125/250 VDC ungrounded system with IMD

Systems with mixed AC/DC power or power conversion equipment, such as variable frequency drives (VFD / ASD), require special measurement techniques. Measurement requires functioning properly throughout a system with no isolation on both the AC and DC side. Additionally, power conversion equipment may add significant leakage capacitance to the system. Insulation monitors must provide accurate readings while overcoming these challenges.

The AMP Plus measurement principle, used in devices such as the iso685, can be used universally in AC, DC, and mixed AC/DC systems. The measurement technique is able to overcome system conditions adverse to measurement, such as high leakage capacitances.

Fault location in ungrounded systems

Previously, fault location on ungrounded systems was a cumbersome process, requiring techniques such as opening and closing branch circuit breakers - taking equipment offline to see if faults cleared. Now, however, devices are available to easily locate ground faults while keeping the system and its loads online.

A control device equipped with a pulse generator are installed in the system. This device may be permanently installed as part of a fault location system, or temporarily added to the system as part of a portable fault-location system.

The device sends a low-magnitude signal into the system. The signal will flow through a fault to ground, and return to the pulse generator.

The signal can be detected with special monitoring devices, either with permanently installed current transformers or a hand-held current probe. Using this method, ground faults can be located down to the faulty load while the system remains online.

Fault location with fixed equipment

A permanently installed system is ideal for systems where 24/7 monitoring is desired. Such systems mitigate the need for regular fault location maintenance, as located faults are reported automatically as they occur. A typical system consists of the following components:

- iso685 ground-fault detector and controller
- EDS440 series ground-fault location modules
- W series current transformers

The iso685 is the ground-fault detector as well as the fault location-system controller. Once a fault is detected, the iso685 begins generating a tracer signal. Each EDS440 device monitors up to twelve branches via current transformers. The EDS440 monitors each channel for this tracer signal. Once the signal is located, its identity is shown on the iso685.

Fault location with portable equipment

Portable fault location equipment can be used as a complement to a fixed system or standalone. Pulse generation is initiated either automatically from an installed iso685, or from a portable pulse generator. The tracer signal is located using a hand-held sensor from an EDS3090 kit. Portable systems are ideal for service technicians and facilities with preventative maintenance programs.

Technical & application information

Grounded systems

Solidly grounded power systems

In a solidly grounded power system, the neutral is connected to ground with a solid neutral-to-ground bond. Solidly grounded systems are common in North America. Typical single-phase configurations include center-tapped 240/120 V transformers, powering most residential homes. Typical three-phase configurations include 208/120 V and 480/277 V, wye-configured transformers. In all of these configurations, the neutral point is bonded solidly to ground. Refer to Figure 4 for an example of a solidly grounded three-phase system with no ground fault.

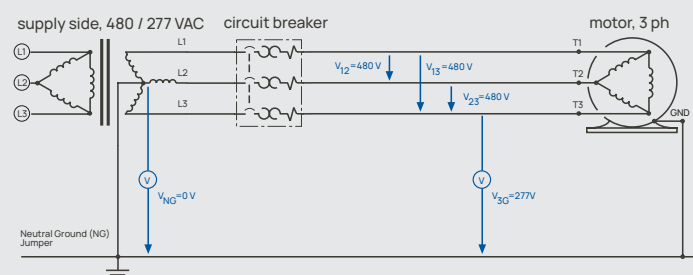

Figure 4: Simplified wye-configured, 480/277 V three-phase system

In a solidly grounded system, current will flow in a first-fault situation. Whereas fault detection in an ungrounded system is intended to be more of a preventative action, fault detection in a grounded system is designed to be more of a reactive action. Fault current can be very large and is detected quickly by conventional current monitoring devices, such as ground fault circuit interrupters (GFCI), circuit breakers, and ground-fault relays.

The magnitude of fault current is dependent on the system voltage and the impedance of the ground fault. Even in a first-fault scenario, severe ground faults can be orders of magnitude higher than the nominal load current. Consider the following formula for calculating fault current:

$$I_F = \frac{V_{3G}}{R_{GF} + R_{GR} + R_{NG}}$$

IF	Fault current
V3G	Voltage between faulted phase and ground
RGF	Resistance value at shorted point
RGR	Resistance of ground path
RNG	Resistance of neutral-ground bond

Using the formula, consider a near-complete short on a 480/277 V system:

$$\frac{277 \text{ V}}{0.1 \Omega + 0.2 \Omega + 0.1 \Omega} = 692.5 \text{ A}$$

Without proper system protection, a ground fault can be devastating, creating risks to personnel and equipment, or causing electrical fires.

Ground fault relays on grounded systems

A common method of ground-fault detection on grounded systems is the “zero-sequence” method. A current transformer (CT) connected to a ground-fault relay is placed around all active conductors (including the neutral, if one is used) for a circuit or system. Refer to Figure 5.

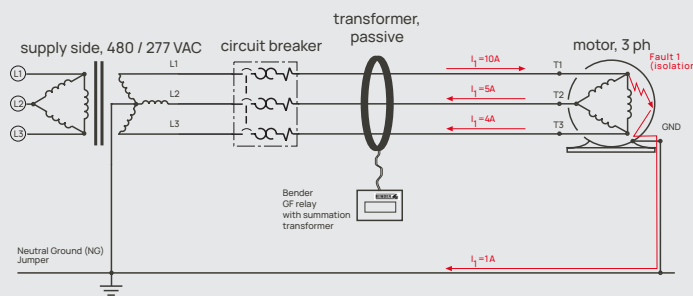

Figure 5: Faulted three-phase grounded system with zero-sequence relay

In a healthy system, according to Kirchhoff's law, the current going out to a load will be the same as the current coming back to the source, in opposite directions. To the current transformer, these equal and opposite values cancel, and the CT measures zero.

When a ground fault occurs, some current will travel through ground, back to the supply neutral and “bypass” the CT. This creates an imbalance in the zero-sequence measurement equal to the fault current. The ground fault relay will measure this imbalance and respond accordingly. Typical actions include tripping a circuit or providing notification to a PLC or industrial network.

Figure 5 shows an example of a 10 A load with a 1 A ground fault. In this scenario, 10 A goes out to the load. However, 1 A travels to ground via a ground fault. Only 9 A returns to the source over the power conductors. The CT measures an imbalance of 1 A in this scenario.

Grounded DC systems

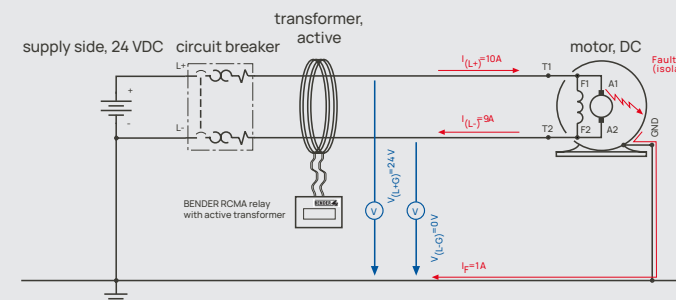

Figure 6: Grounded DC power system

Figure 6 shows a simplified grounded DC system. Typically, the negative pole of the DC power supply is connected to a chassis or building ground. Ground-fault current detection is principally the same as an AC system - a ground fault will cause a load current imbalance, which is measured and processed. DC systems however, require special active current transformers for proper monitoring. Bender AC/DC relays equipment, such as the RCMA420, combined with special current transformers, are able to accurately measure DC current.

Variable frequency drives

Typical ground-fault relays for 50/60 Hz systems may encounter problems when monitoring systems with variable frequency drives (VFD / ASD). A drive converts incoming AC power to DC (rectification) and then converts the DC back into controlled-frequency AC inversion, which powers the load, usually a motor. Issues that typical ground-fault relays may encounter include:

- Inability to detect DC ground fault internal to drive
- Inability to detect low-frequency AC faults
- EMI filter circuitry adding to overall system leakage
- Interference from carrier frequencies
- Harmonic content interfering with measurements

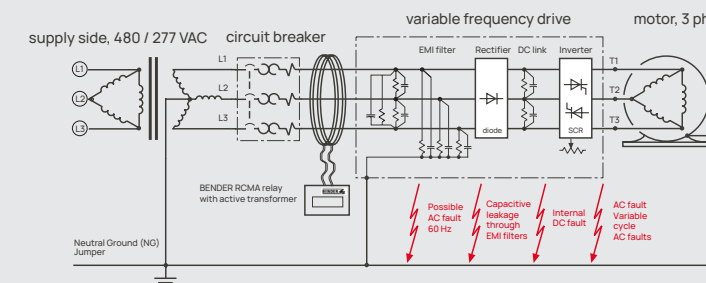

Figure 7: Grounded system with variable frequency drive

Bender RCMA and RCMS series relays employ active monitoring technology and built-in filtering to accurately measure ground faults throughout the entire power conversion process found in low-voltage variable-frequency drives.

Resistance grounded systems

In a resistance grounded system, a purpose-built neutral grounding resistor (NGR) is connected between neutral and ground. The NGR limits ground-fault current to a low value. In a low-voltage system (up to 600 V), limiting current to 10 A or less is commonly known as high-resistance grounding (HRG).

An HRG system has the benefits of both ungrounded and solidly grounded systems, without their inherent drawbacks. An HRG system can typically continue to operate in a single-fault condition, while having sufficient fault current for detection and location by ground-fault relays. On systems utilizing circuit interruption, multi-channel relays such as the RCMS series can isolate faulty circuits while allowing the rest of the system to continue operation.

NGR's can be susceptible to failure, caused by factors such as thermal-cycling stress and corrosive environments. Additional monitoring of the NGR is required to ensure proper operation, as an NGR loss will render conventional ground-fault protection inoperable. Devices such as the NGRM700 provide a combination of ground fault and NGR monitoring.

Codes & standards reference guide

General Purpose

Description	Requirements	Applicable Products
Ground-fault detection for ungrounded AC systems	USA: NEC 250.21(B) Canada: CEC 10-400	iso685 series
Ground-fault detection for ungrounded DC systems	USA: NEC 250.167(A) Canada: CEC 10-400	iso685 series
Ground-fault detection for grounded DC systems	USA: NEC 250.167(B)	RCMA420 / 423 series RCMS series
Ground-fault protection for electric heat tracing systems	USA: NEC 427.22 Canada: CEC 62-116	RCM420 series RCMS series
Service entrance ground-fault protection	USA: NEC 230.95 Canada: CEC 14-102(2)	CMGF420
Ground-fault protection for emergency systems (standby generators, etc.)	USA: NEC 700.6 (D)	CMGF420
Neutral-grounding resistor protection	Canada: CEC 10-302	NGRM500 & NGRM700

Healthcare facilities

Description	Requirements	Applicable Products
Installation and monitoring requirements, isolated power systems	USA: NEC 517.160 Canada: CEC 24-200	LIM2010 Isolated power panels
Requirements for use, isolated power systems	USA: NFPA 99 Canada: CEC 24-116	LIM2010 Isolated power panels
Product standards, isolated power systems	UL1047, UL1022, CSA Z32	LIM2010 Isolated power panels

Renewable energy supply and storage systems

Description	Requirements	Applicable Products
Grounded solar arrays	USA: NEC 2017 690.41(B), 2014 690.5 Canada: CEC 64-064(4)	RCMA423 series RCMS series
Ungrounded solar arrays	USA: NEC 2017 690.41(B), 2014 690.35 Canada: CEC 64-066(1)(d)	isoPV series iso1685P series
Electric vehicle charging stations (EVSE)	USA: NEC 625, SAE J1772, UL2231-2	RCMB101 (Level 2) IR155-10 (Level 3 / Fast DC)
Energy storage systems, DC microgrids	USA: NEC 706.30(D), 705.32, 712.55	RCMA423 series iso1685P series
Ground-fault protection for inverters	UL1741	RCMA423 series

Other industry-specific requirements

Description	Requirements	Applicable Products
Marinas and shore power	USA: NEC 555.35, NFPA 303 Canada: CEC 78-052	MarinaGuard® series
Mines and mining equipment	USA: MSHA CFR 18.47(d)(2) Canada: CSA M421 and CEC	RC48N / RC48C series RCMA423 series NGRM500 & NGRM700 RCMS490 series
Fountains, spas, submersible pumps	USA: NEC 680.51(A) Canada: CEC 68-068	LifeGuard® series

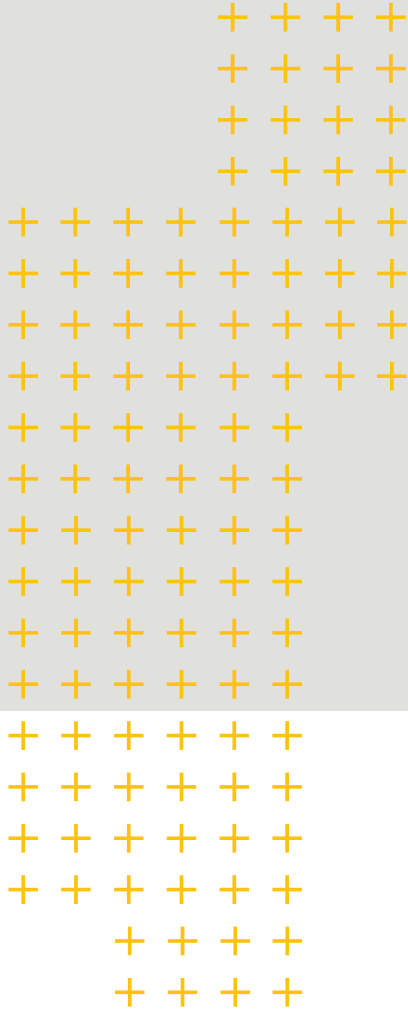

USA • Exton, PA
+1 800.356.4266
info@benderinc.com
www.benderinc.com

Canada • Mississauga, ON
+1 800.243.2438
info@bender-ca.com
www.benderinc.com

14.3G.REV.5 | 09.2023 | © Bender Inc. All Rights Reserved.

